

SUPER SERIES MODELS C-20 & C-30 COMBO Automatic Rack Merchandiser Service Manual

GENERAL

The Super Series machines have been developed specifically for the display merchandising market. Each of the dispensing units may be activated by push button selection of a letter (A to E) and a number (0 to 9) after sufficient credit has been established in the coin mechanism.

Two types of module dispensers (Spindle and Helix) are supplied for optimum production selection. Dispensers are readily removable from the front for replacement or repair.

COMBO-30 SPECIFICATIONS

SPECIFICATIONS

OVERALL DIMENSIONS:

Height 72"
Width 37"
Depth 28½"
Weight (Approx.) 470 pounds

ELECTRICAL:

Primary 110-125 VAC
Secondary 24 VAC
Current (primary) 2 AMP

CAPACITY:

EACH

15 Large Spindles 10 pieces
1 Candy Tray 10-Selection
1 Pastry Tray 5-Selection

Helix Dispensers

3/4" pitch 22 pieces (crackers & candy)
1 1/8" pitch 16 pieces (crackers & candy)
1 3/8" pitch 12 pieces (crackers & candy)
1 5/8" pitch 10 pieces (crackers & candy)

1 1/8" pitch 14 pieces (chips & pastry)
1 5/8" pitch 10 pieces (chips & pastry)
2" pitch 8 pieces (chips & pastry)

COMBO-20 SPECIFICATIONS

SPECIFICATIONS

OVERALL DIMENSIONS:

Height 66½"
Width 31¼"
Depth 28½"
Weight (Approx.) 470 pounds

ELECTRICAL:

Primary 110-125 VAC
Secondary 24 VAC
Current (primary) 2 AMP

CAPACITY:

EACH
8 Spindles for Chips 10 pieces
1 Pastry Tray 4-Selection
1 Candy Tray 8-Selection

For service call Polyvend at 1-800-643-8250 or 501-327-1301

INSTALLATION INSTRUCTIONS

In order to comply with electrical regulations and Underwriter's Laboratories requirements, all electrical equipment must be properly polarized and grounded. The Polyvend machine is wired so that it is properly polarized in accordance with the electrical code. If the wall outlet is wired and grounded properly, then the vendor will connect properly.

Shown in view A and B are two properly grounded and polarized wall outlets. One is a three wire grounded type wall outlet (see View A), and one is a two wire wall outlet (see View B) with an adapter in place. To make a polarity check, use a 115 volt neon test lamp as shown, or a volt ohm meter. The hot side of the circuit should always be counterclockwise from the ground terminal, (which should be at the bottom).

Should the polarity at the wall outlet show any way other than that shown below, the outlet should be rewired.

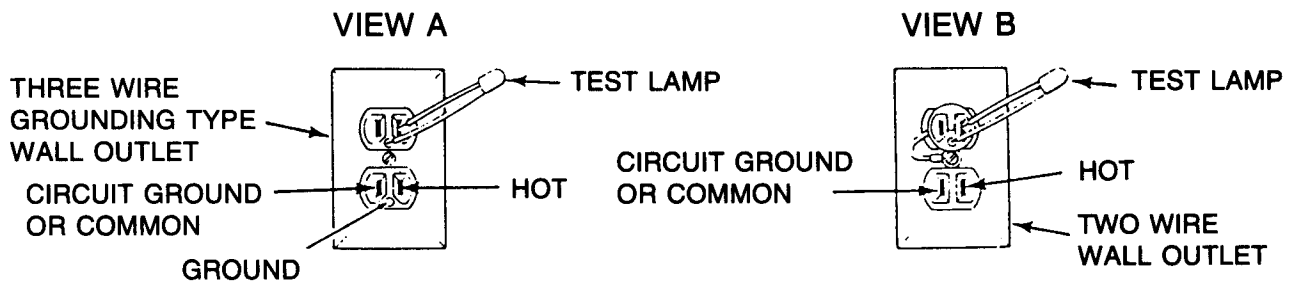

INSTALLATION

- Cut shrink wrap at a point over cardboard to avoid damage to cabinet finish.
- Inspect for damage resulting from improper handling and, if evident, file claim immediately with the carrier.
- Place machine into position and adjust leveling legs so it is level and all legs touch the floor.
- To install Wall Mounting Option, see Appendix B.
- Locate small envelope inside delivery compartment and remove keys.
- Open service door and remove all internal packing material. (There are different numbered keys in envelope—one for the service door, two for the back door, and (if option selected) one for coin bank lock.
- Remove price stickers from envelope shipped in delivery compartment and select the appropriate ones to match desired pricing of products.
- Peel off the adhesive backing and place selected price stickers on their respective dispenser locations.
- Remove tape from coin return cup.
- Save extra fuses, etc. found in the envelopes.
- Plug machine into the wall electrical outlet. Set controller to the desired price levels in accordance with the instruction sheet or the instructions provided in the “Price Setting” section of this manual.
- Verify that the proper selection operated with the selection made on selector keypad.
- With controller in service mode refer to electrical section of this manual. Press button “2” on the selector switch panel and the display will display “30” or if Gum & Mint installed “35”. On the C-20, it will display 20, or 24 if Gum & Mint installed. If not refer to trouble-shooter section as a motor or motors are missing.
- Check operation of the service door and lock.
- Check proper operation of vending mechanisms with coins.
- Load the machine with product. (See “Product Loading”)
- Close the sliding drawer on the right of the machine.
- Close and lock the service door.



PRICE SETTING INSTRUCTIONS

1. Open the service door and pull out the sliding drawer to obtain access to the controller board. Locate the controller board directly behind the coin mechanism.
2. Push MODE switch (top switch on the controller board) and release. (See controller picture to the right.)
3. Make any selection by pressing a letter and a number. The current price will be displayed. To increase price in nickle increments; press "9". To decrease price; press "4". When desired price is reached, release the button. If more selections are to be set at the same price press "5". (The beeper will turn on and off repeatably during this mode.) Now press each selection to be set at this price. (First the "letter", then the "number".) Pressing "0" will return you to the service mode. Repeat step 3 until all selection prices have been set. The Vendor can be returned to the Sales Mode by pressing the Mode Switch again or it will automatically return to the sales mode 25 seconds after the operation has been made. **DO NOT** forget to label the end of the cover bar or tray with the appropriate price sticker.

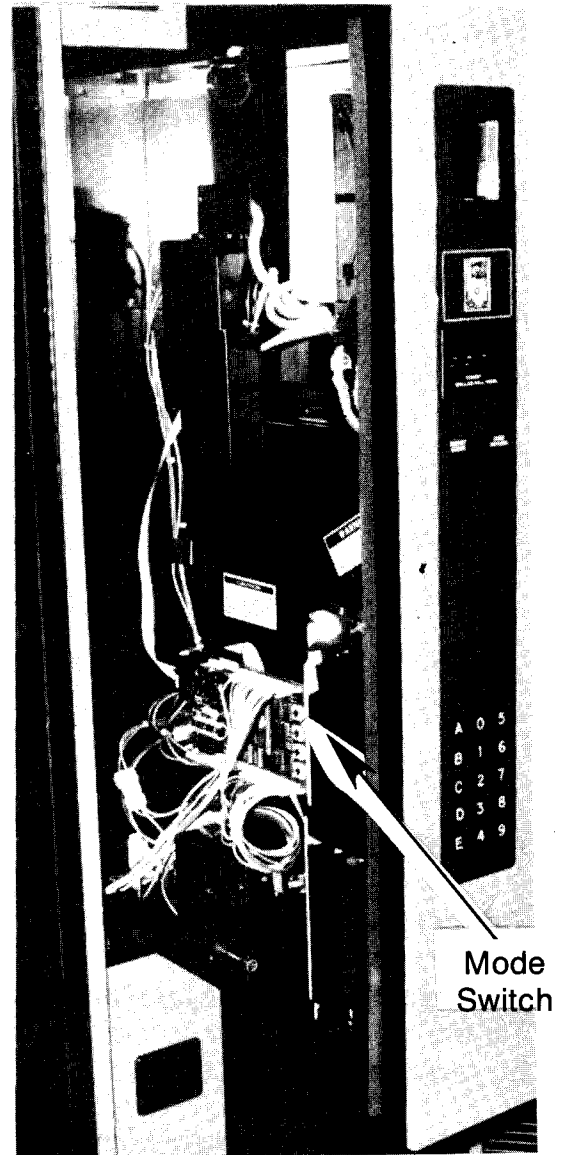

4. To free vend or test vend:
Press Mode Switch to place the Controller in the Service Mode, then:
 - To run all selections, press "8". Each selection will run in turn showing first the selection number then the price of that selection in turn starting with "E" and the highest number in each row*.
 - To run 1 horizontal row (eg. "A"), press "7", then press row letter. Each selection in that row will run in turn starting with the highest number*.
 - To run individual selections, press "6" then the selection letter and number.

NOTE: To STOP a function such as vending all selections press and hold "0" until the operation stops.

*In this mode, "0" is considered to be the highest number.



The three "INVENTORY" switches below the "MODE" switch are for use with the Mars 5010, and TRC 6010 coin mechanism; and the Coinco 9302L Coin Mechanism.

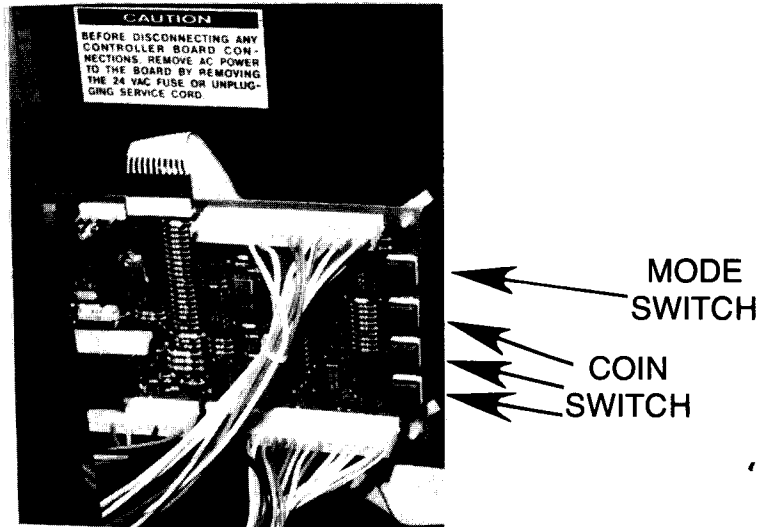

FIGURE 1

COIN COLLECTION

The coin bank is located as shown below the coin mechanisms and is accessible when the front door is opened. An optional lock and key are available to provide additional security. To open, insert the key, press in and rotate 1/4 turn counterclockwise to unlock the bank. Tilt the top of the bank to the left until it can be lifted out. Remove the coins and replace by reversing the procedure.

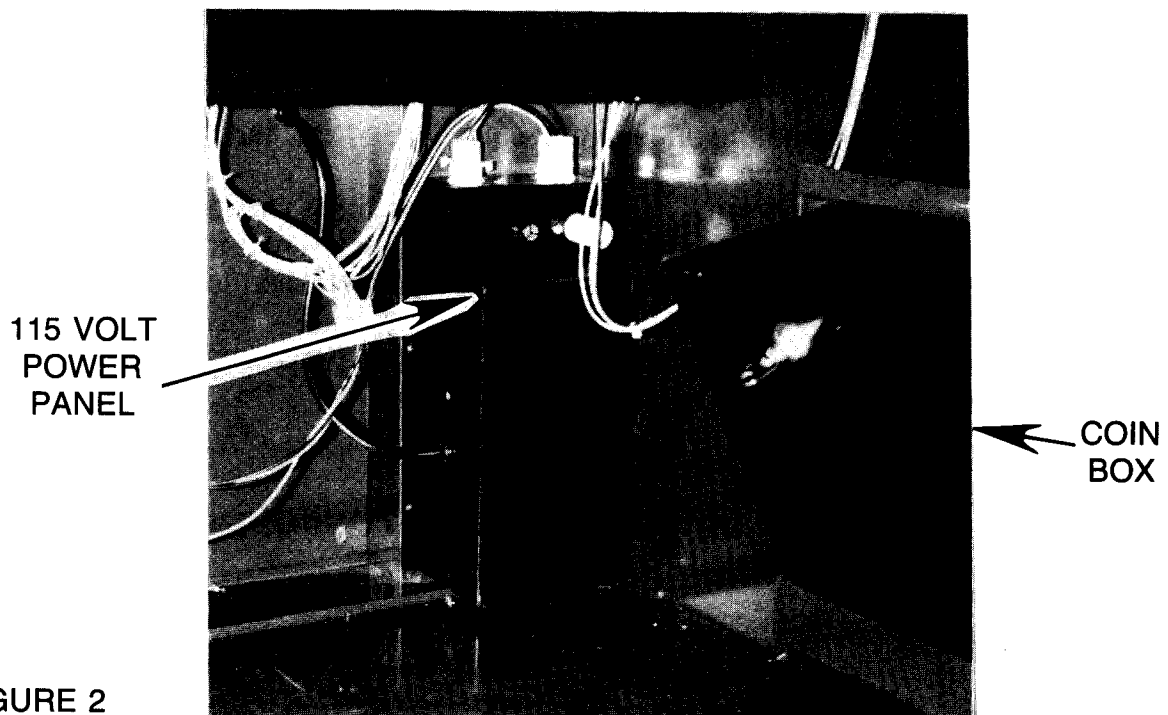

FIGURE 2



PRODUCT LOADING—CHIP CONVEYORS

All product loading of the machine is accomplished from the front. Using one of the two keys provided, open the service door. This provides access to all dispensers.

To load any dispenser, pull and lift the cover bar assembly and gently pull the helix conveyor out of its socket, (see FIG. 3). Hold it by the front tip and load all new products face forward over the rear hub to maintain a "first out" product flow. After loading, there should be one product on each position of the conveyor (see FIG. 4).

To insert loaded conveyor, lift up on cover bar assembly and push firmly into the motor socket until a "snap" is felt. This "snap" is the detent spring engaging, which assures the conveyor is fully seated and cannot fall out. Pull and lower the cover bar so the pin is reinserted into the large end of the spindle.

The procedure is repeated for each dispenser until the machine is fully loaded.



FIGURE 3



FIGURE 4

PRODUCT LOADING OF HELIX TRAYS (CANDY & PASTRY)

HELIX DISPENSER

If needed for narrow products use spacer rail.

FOR ADDITIONAL RAILS ORDER:

P/N 18244-02 for models C-20 and C-30 series.

PRESS ON SPACER RAIL

INSTALL AS SHOWN (Reversible to adjust spacing)

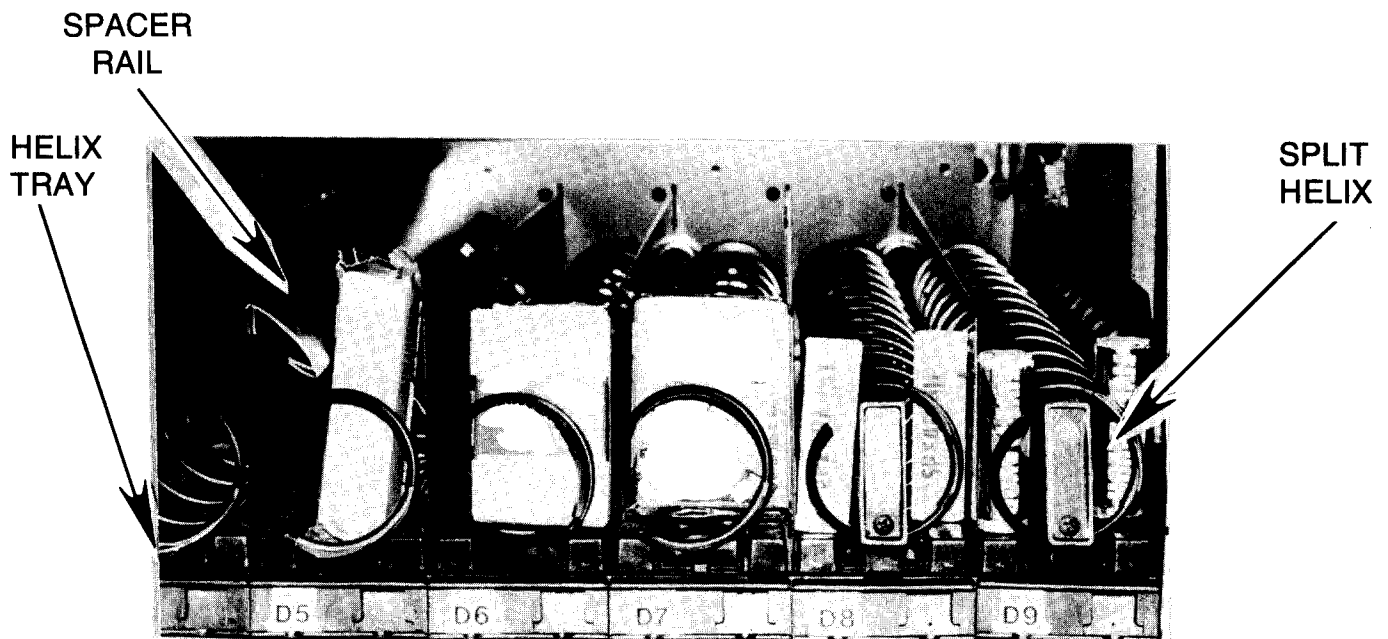

FIGURE 5

TALL PRODUCT SHOULD REST
ON TRAY NOT ON HELIX



PRODUCT LOADING OF GUM & MINT DISPENSERS

This five select gum, mint or tube candy dispenser is available in kit form or can be installed at the factory at the time your machine is built. Each module will hold twenty-four (24) items up to one inch in diameter, and five inches in length. All machines are prewired from the factory (see figure 13 on page 16). The unused harness plugs to the motor harness installed on the kit. See installation instructions on next page.

Loading Instructions

1. Lift and pull module forward, clear of tracks.
2. Remove side plate and load product. (See below)
3. Re-install side plate and reverse procedure #1.
4. Re-program machine.

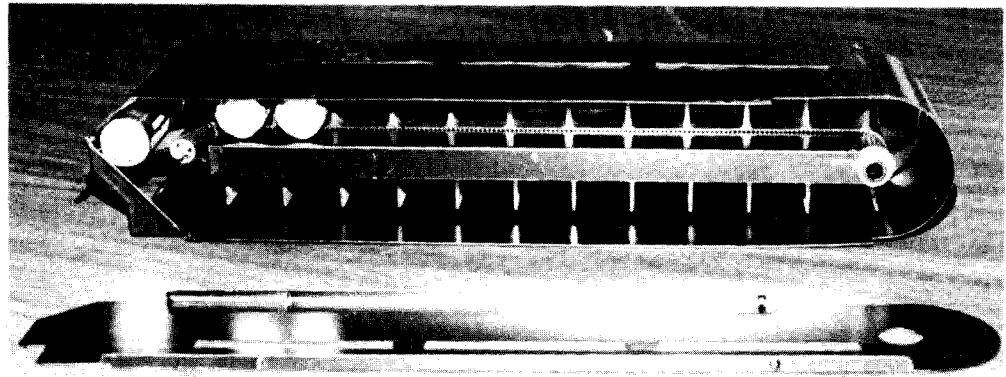

LOADING
POSITION

FIGURE 6

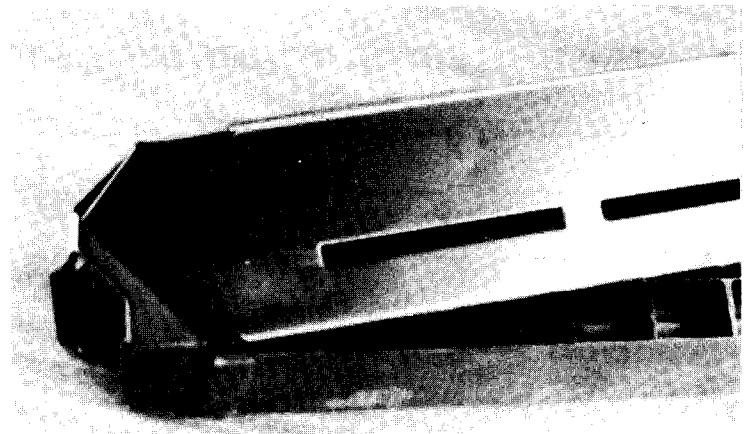

Snap cover in position with leading edge of cover under bracket as shown.

FIGURE 7

GUM & MINT INSTALLATION INSTRUCTIONS

1. Remove deflector from front of false bottom and discard screws and deflector.
2. Attach retrofit plate assembly by sliding plate under false bottom so that lip engages front edge of false bottom (use 2 large screws provided), and connect harness to mating plug near power box.
3. Attach hinged cowling. (Use 2 small screws provided.)
4. Tilt cowling up and slide modules into tracks on retrofit plate as illustrated. Lift up on front of module during last few inches of travel to allow front stop block to fall into notch in track.

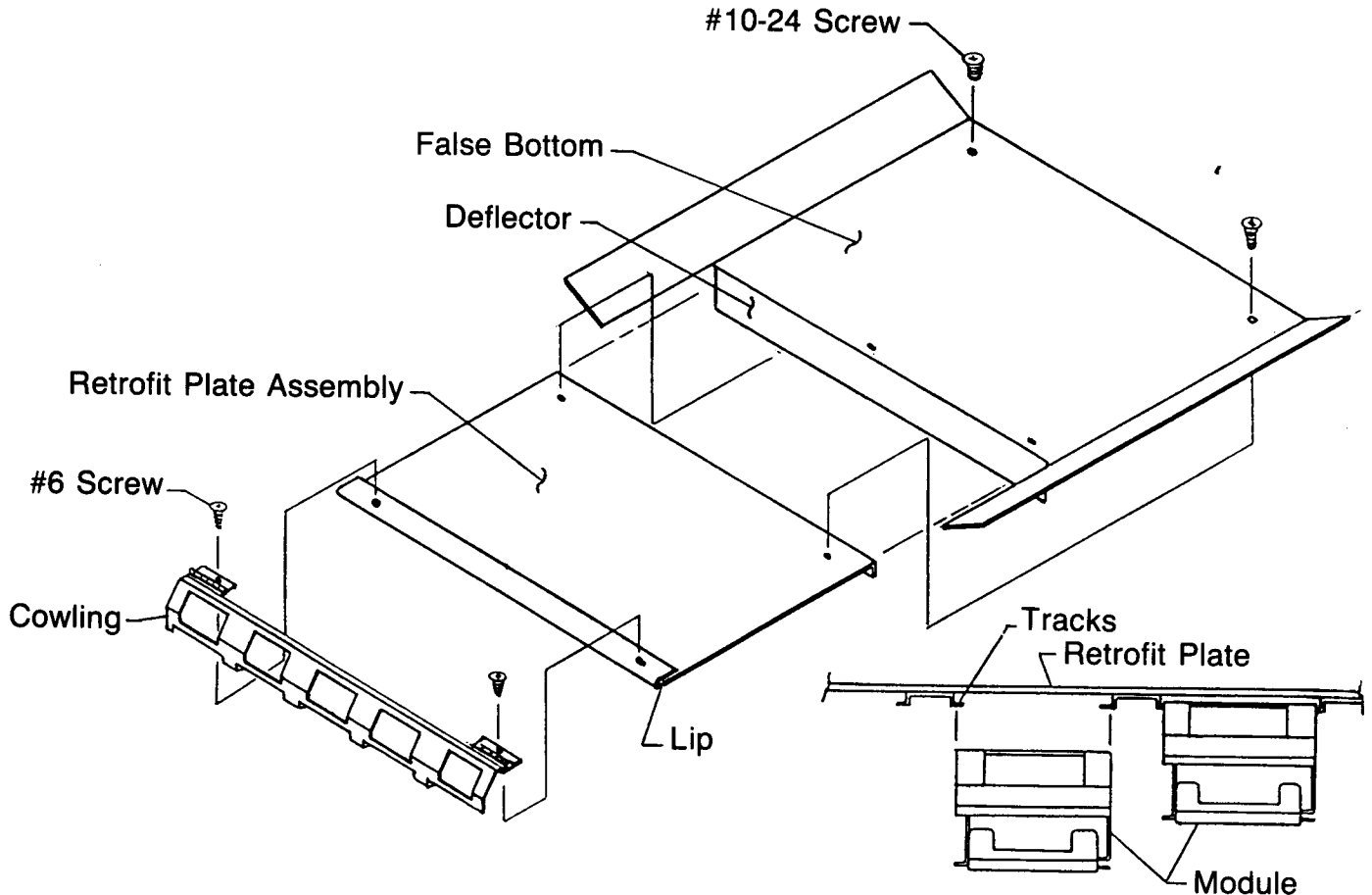

5. ATTACH SELECTION NUMBER DECALS TO COWLING FRONT AS FOLLOWS:
Model: Tom's Super 35

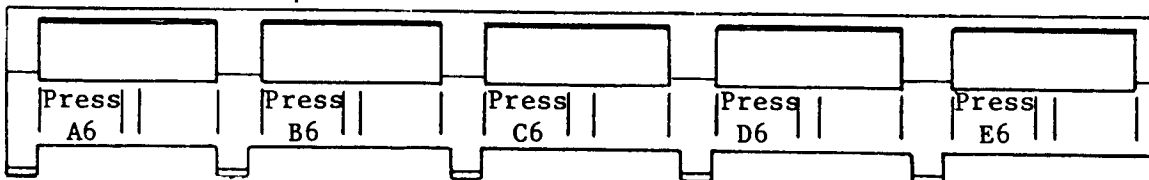

Model: PV4000 & 5000 Series

Press A5	Press A6	Press A7	Press A8	Press A9
-------------	-------------	-------------	-------------	-------------

Model: Tom's Spindle & Helix Combo

Push A6	Push A7	Push A8	Push B6	Push B7
------------	------------	------------	------------	------------

1 2 3 4 5 6 7

A B C D E F G H I J K

REV	DATE	DESCRIPTION	BY
M	11/11/68	PROD. REL.	REL
21399			

REV	DATE	DESCRIPTION	BY
1		RAIL W/A - SUN & MINT	
2		COVER - PRODUCT	
3		ORGT-PUSHER SPRING SET	
4		CHANNEL - PUSHER STOP	
5		PLATE - MOTOR	
6		PLATE - MOTOR	
7		PLATE - MOTOR	
8		PLATE - MOTOR	
9		PLATE - MOTOR	
10		PLATE - MOTOR	
11		PLATE - MOTOR	
12		PLATE - MOTOR	
13		PLATE - MOTOR	
14		PLATE - MOTOR	
15		PLATE - MOTOR	
16		PLATE - MOTOR	
17		PLATE - MOTOR	
18		PLATE - MOTOR	
19		PLATE - MOTOR	
20		PLATE - MOTOR	
21		PLATE - MOTOR	
22		PLATE - MOTOR	
23		PLATE - MOTOR	
24		PLATE - MOTOR	
25		PLATE - MOTOR	
26		PLATE - MOTOR	
27		PLATE - MOTOR	
28		PLATE - MOTOR	
29		PLATE - MOTOR	
30		PLATE - MOTOR	
31		PLATE - MOTOR	
32		PLATE - MOTOR	
33		PLATE - MOTOR	
34		PLATE - MOTOR	
35		PLATE - MOTOR	
36		PLATE - MOTOR	
37		PLATE - MOTOR	
38		PLATE - MOTOR	
39		PLATE - MOTOR	
40		PLATE - MOTOR	
41		PLATE - MOTOR	
42		PLATE - MOTOR	
43		PLATE - MOTOR	
44		PLATE - MOTOR	
45		PLATE - MOTOR	

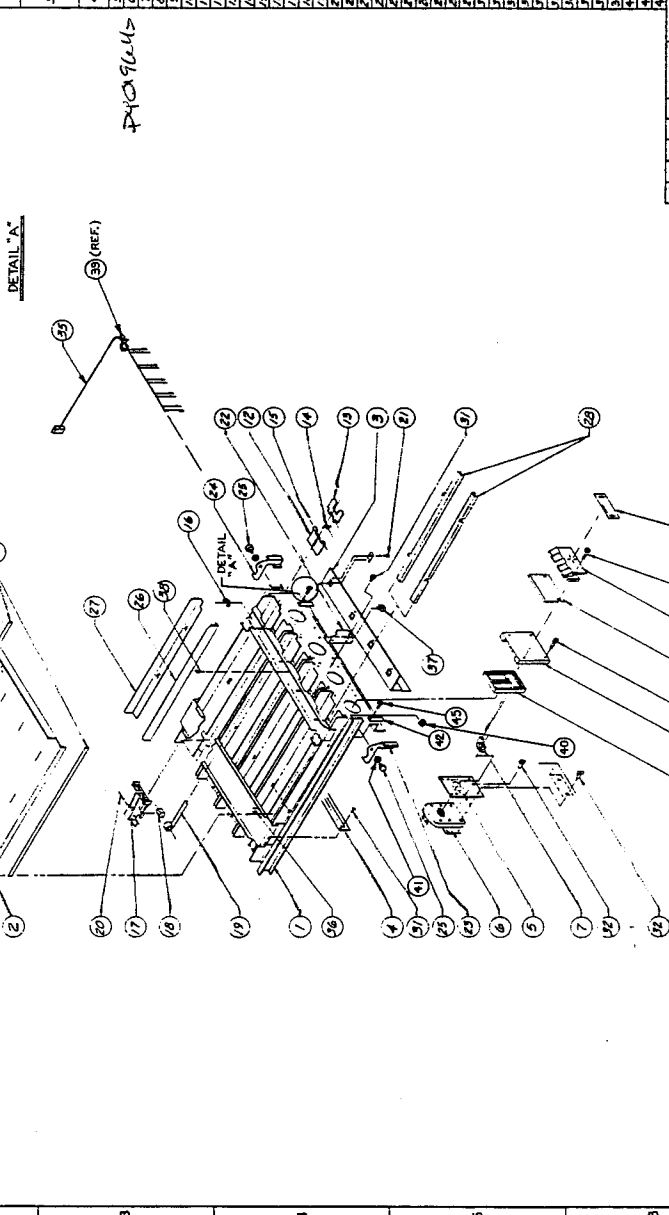

REV	DATE	DESCRIPTION	BY
1		RAIL W/A - SUN & MINT	
2		COVER - PRODUCT	
3		ORGT-PUSHER SPRING SET	
4		CHANNEL - PUSHER STOP	
5		PLATE - MOTOR	
6		PLATE - MOTOR	
7		PLATE - MOTOR	
8		PLATE - MOTOR	
9		PLATE - MOTOR	
10		PLATE - MOTOR	
11		PLATE - MOTOR	
12		PLATE - MOTOR	
13		PLATE - MOTOR	
14		PLATE - MOTOR	
15		PLATE - MOTOR	
16		PLATE - MOTOR	
17		PLATE - MOTOR	
18		PLATE - MOTOR	
19		PLATE - MOTOR	
20		PLATE - MOTOR	
21		PLATE - MOTOR	
22		PLATE - MOTOR	
23		PLATE - MOTOR	
24		PLATE - MOTOR	
25		PLATE - MOTOR	
26		PLATE - MOTOR	
27		PLATE - MOTOR	
28		PLATE - MOTOR	
29		PLATE - MOTOR	
30		PLATE - MOTOR	
31		PLATE - MOTOR	
32		PLATE - MOTOR	
33		PLATE - MOTOR	
34		PLATE - MOTOR	
35		PLATE - MOTOR	
36		PLATE - MOTOR	
37		PLATE - MOTOR	
38		PLATE - MOTOR	
39		PLATE - MOTOR	
40		PLATE - MOTOR	
41		PLATE - MOTOR	
42		PLATE - MOTOR	
43		PLATE - MOTOR	
44		PLATE - MOTOR	
45		PLATE - MOTOR	

polyvend
CONWAY, ARKANSAS

HELIX TRAY DISPENSERS

There are several helix pitches. To assure proper operation and maximum capacity, the product size should closely match the opening between the winding of the helix. The product should fit between the windings of the helix so as **NOT** to be tight but should fill most of the opening.

The helix sizes listed below may be used:

- 3/4" Helix (Thinnest Candy Bar)
- 1 1/8" Helix (Thin Candy Bar)
- 1 3/8" Helix (Medium Candy Bar)
- 1 5/8" Helix (Large Candy Bar)
- 2" Helix (Chip & Pastry)
- 1 5/8" Helix (Medium Chip or Pastry)
- 1 1/8" Helix (Large Cookies)



To load, release the white plastic stop on bottom right of tray. Lift the front edge of the helix tray while pulling forward on the tray. Pull the tray out until it hits stop. Then let it tilt down into the loading position.

At this point, check that each helix is in its proper position. The figure shows proper and improperly positioned helices.

Starting at front of the tray, insert product between each winding of the helix so that the name of the product is displayed frontward. Be sure to place product all the way to the bottom of the tray and tilt free end at top backwards. Fill from front to back and be sure not to miss any positions. After filling, lift front of tray back until the latch is engaged. Check that latch is fully engaged by pulling forward on tray and ensuring that the tray does not advance beyond latch.

Both C-20 and C-30

FIGURE 8

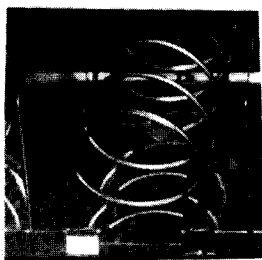

Candy Helix in
Detent Position

FIGURE 9

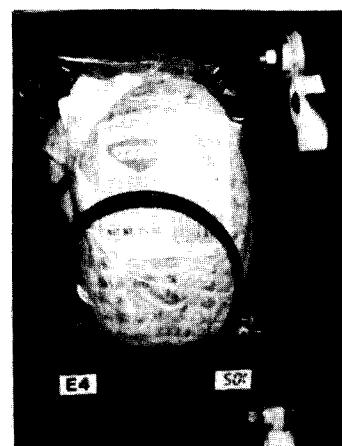

Chip (Large) Helix
in Detent Position



NOTICE

Special loading instructions for box type product or thick flat bottom candy.

Candy Tray Only!!

Certain candies and cigarettes have flat or semi-flat bottoms which are thick and wide. Polyvend has designed into our helix the flexibility to be 100% sure of the vending of this type of product. By moving the position of the helix and thus the kicker, it ensures the best dispensing for boxed products. You simply unlock the helix by twisting the helix counterclockwise and continuing the rotation 90 degrees, and relock the helix by twisting clockwise 10 to 15 degrees. The helix should be in the position as shown below.

FIGURE 10

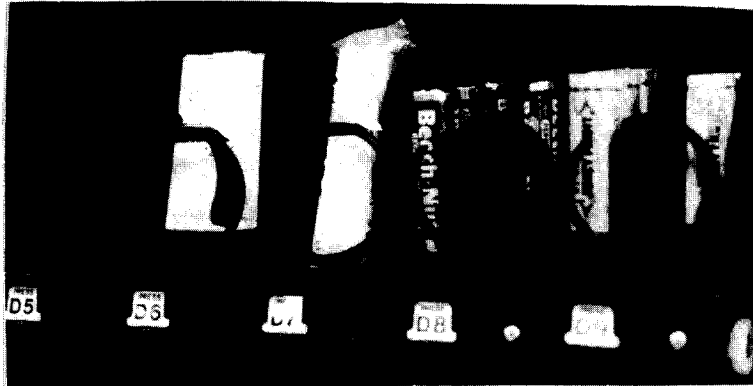

Kicker 90 degrees from normal for thick or box type product.

Kicker at bottom normal

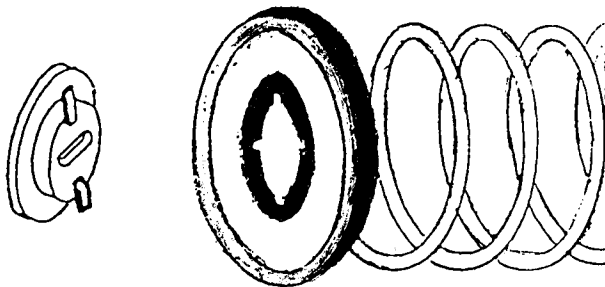

As you can see, the coupling has two locking pins and the hub has four slots. Unlock by twisting left and lock by twisting right.

FIGURE 11

HELIX DISPENSERS

Visual observation of the helix trays and the assembly drawing will aid in the repair of these assemblies. However, notice of the following instructions will further reduce handling:

HELIX REMOVAL

An individual helix can be removed for cleaning, repair, or replacement with a different pitch while the tray is either in or out of the machine by grasping the helix and twisting 10 to 15 degrees clockwise. Check to verify proper position of helix end (page 13) and pull to ensure proper latching.

HELIX TRAY REMOVAL

Lift the white cam on the right side of the helix tray to clear latch and pull forward until contacting the stop that allows the tray to tilt down for loading. Then disconnect the harness and lift the front of the tray and lift the same white cam while pulling forward. To clear the machine, grasp the tray at front and back, lift it out to place on a work surface.

To replace, reverse the operation. Grasp the tray, engage the rear rollers in the track and slide the tray high to clear the stop and push into the loading position. Load product, lift, and push into the latched position.

DISPENSERS

FIG. 12 illustrates the dispenser until used in the Super Series. The basic components as labeled in FIG. 12 are:

- (1) Cover Bar
- (2) Spindle Conveyor
- (3) Motor Assembly

When a product selection is made (see section E of operation), an electric signal starts the motor, turning the helical conveyor one complete rotation. this operation advances all products forward dispensing the front selection into the delivery compartment.

The cover bar has three functions. It discourages theft through shaking the machine, provides a number on the front tab for product selection with the matching number on the selector switch assembly, and presents a more attractive appearance to the machine by concealing the conveyor.

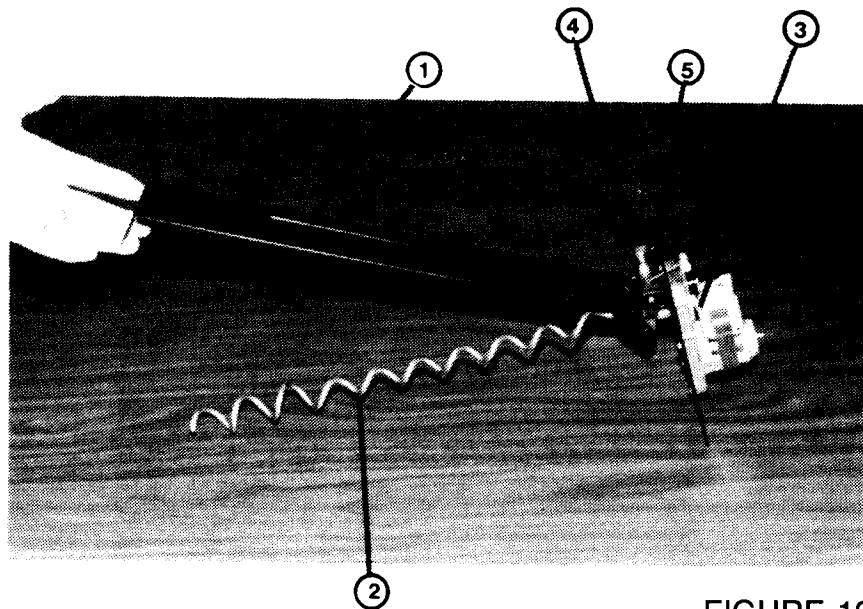
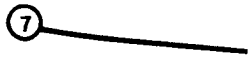

FIGURE 12

INDEX	PART NO.	DESCRIPTION
1	17321	Cover Bar - Black
2	17343	Conveyor, 15 Positions
2	17342	Conveyor, 10 Positions
3	17488	Motor Assy. - D.C. - Black
4	14383	Pivot Pin
5	14318	Cover Bar Spring
6	18169	Selection Decal
7	17311-03 thru -08	Price Decal



CONTROL PANEL DRAWER ASSEMBLY

With service door open, pull drawer to the stop. Reach up from below the "Display Bottom" to the rear of the drawer and disconnect the two harness connections. Pull drawer to full open. Remove (4) screws from slide in center of drawer. Two must be removed through the large hole in center slide section. Be careful **NOT** to allow drawer to fall when removing these screws then lift and remove from guides. Reverse this procedure to reinstall.

REAR ACCESS PANEL

A large access panel is provided on the rear of the machine. Its only purpose is to permit access to the wiring in the rear of the machine. To remove it, remove the screws behind motors B-0 & B-4 on the C-30 and B-0 & B-3 on the C-20. Pull top away from cabinet then lift the bottom of the door away from the cabinet and remove. Handle carefully to prevent dropping and damage.

NOTE: All motors can be removed from the front for servicing.

STORAGE COMPARTMENT

The storage compartment is shown below the product display area and is accessed by opening the front door. Leave room for the delivery compartment when using the storage area.



FIGURE 13

ELECTRICAL SERVICE

The Super Series Rack Merchandiser operates from a primary power source of 115 volts, 60 hz. This power source is reduced through a transformer to a secondary source of 24 volts at 60 hz. which supplies power to the entire machine with the exception of the fluorescent lighting. The low voltage system offers greater protection in the servicing and maintenance of the machine. The electrical schematic shows the entire electrical system.

The power box assembly contains all primary voltage components that have exposed terminals and is enclosed for safety of service personnel. If it is necessary to service internal components, always unplug the machine from the wall before removing the box from the compartment. The power panel is located in the right rear corner of the storage compartment.



ELECTRICAL SERVICE Cont.

The lamp starter and fuses can be safely replaced by simple turning the component and pulling. Then replace with new part.

Lighting for the Merchandiser is provided by a single 15 watt fluorescent lamp located at the top of the product compartment.

The Vending Machine Controller has an operating capacity of 50 dispensing mechanisms. A Configuration Procedure is automatically performed by the controller when turned on to determine the operating configuration.

ELECTRONIC VENDING MACHINE CONTROLLER

The vending machine controller has two modes of operation: Service and Sales. The Service Mode is used for price setting, trouble-setting and verification of operation. The Sales Mode is the normal mode when ready to dispense products to the customer.

AUTO CONFIGURATION

The Polyvend Phase II Control System is to automatically search the vending machine to determine the configuration of rows and columns. This Auto Configuration cycle is to be activated on power-up and when it leaves the service mode.

The configuration routine is to compare current motor status with the motor status of the previous configuration cycle on power-up. If the system finds more motors, the machine configuration is to be updated with no impairment to operation. If the system finds fewer motors, those motors not present in the new configuration are to be flashed in sequence to the serviceman upon entering the service mode. (Remove motors from configuration.) The new machine configuration is done by depressing button "3" prior to exiting the service mode.

All motor fault indications are to be stored in nonvolatile memory in the event of power outages and automatically reset upon exiting the service mode.

SALES MODE

The sales mode is the primary operational mode for the vending machine. Entering or invoking any other routine or feature always results in a return to the sales mode with no additional input from the machine operator. A valid selection is to consist of the last alpha (A-E) switch depressed followed by the numeric (0-9) switch depressed.

With each transaction, total credit deposited is indicated on the customer display. Each valid customer action is acknowledged with a single, audible tone, or "beep". Invalid actions are called to the customer's attention with three successive "beeps". If change is owed to customer after selection is made, the credit display indicates the amount overpaid.

LCD Credit Display

The LCD display is to be operated according to the following sequence:

If a selection is made and adequate credit has been established, then the display is cleared and the vend operation is completed.

If a selection is made and there is insufficient credit, then "Price" is flashed for approximately 1.5 seconds along with the vend price of the selection.



If a credit from the changer has not taken place within the preceding 24 hours, then a changer status flag is set. At any time, a complete transaction will cause the changer status flag to reset. In the service mode, "Change" is displayed if this "Check Coin Changer" feature is active. The "Check Coin Changer" feature does not affect the operation of the machine should a vend be attempted. It only signifies that the changer may be faulty or jammed.

If a faulty motor condition exists, then the LCD display will indicate "Make Alternate Selection" and 3 beeps will sound. The faulty motor locations are displayed upon entering the service mode.

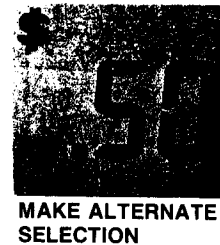

If credit is established and no selection is made, then the LCD display will indicate "Total Deposit" and the amount deposited will be displayed. At the end of a vend cycle or after an escrow, the display will indicate "Total Deposit" and \$0.00.

If exact change is required for a transaction the credit display will read "EXACT CHANGE ONLY". Low inventory in the coin tubes does not prevent the customer from making a selection. If \$ Bill Validator is used, and if quarter tube is low, then the "Exact Change Only" is displayed.

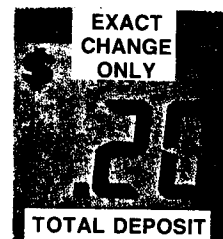

NOTE: When the highest vend price setting is reached the crem coils in the coin changer will fall out to prevent further acceptance of coins until a selection has been made or coin return lever has been actuated.

NOTE: Price Range

Coinco - C300 \$.05 to \$3.15

MARS TRC 6010 & Coinco 9302L to maximum of display \$9.95

SERVICE MODE

GENERAL SPECIFICATIONS

The service mode is to be entered by depressing the "Mode" switch located on the component side of the controller board. The service mode automatically reverts to sales mode if no service related operations have occurred for approximately 25 seconds or if mode button is pushed a second time.

DIAGNOSTICS

Diagnostic information is to be displayed upon entering the service mode. All diagnostic information is cleared upon leaving the service mode. The service mode is exited by actuating the mode button or after approximately 25 seconds without implementing additional service mode features.

Faulty motor locations, if any, are to be displayed in a rotational sequence for 1 second intervals. If a selection is attempted in the sales mode, the LCD display will indicate "Make Alternate Selection" for approximately 1.5 seconds and 3 beeps will sound. The following criteria constitute a motor fault: A motor location drawing in excess of 400 Ma. for approximately 250 Msec. A motor location requiring more than 8 seconds to reach the home position. An electrically open condition at any location.

The "Check Coin Changer" indication will occur if a sale has not been completed in the preceding 24 hours. This condition is indicated when entering the service mode by displaying the word "Change" on the LCD display. Vend operations are not affected by the "Check Coin Changer" indication and only mean that changer may be faulty or jammed.

MEMBRANE KEYPAD DECODING

When operated in the service mode, several keys located on the front panel keypad will have more than one definition as described in the following chart. The function of these keys will be discussed in later paragraphs.

A = A

B = B

C = C

D = D

E = E

0 = 0 or Cancel Multi Price Mode or Vending by row or machine

1 = 1 or Cancel Multi Price Mode or Vending by row or machine

2 = 2 or Display Configuration Number

3 = 3 or Sets Reconfiguration

4 = 4 or Decrement Price

5 = 5 or Set Multiple Price

6 = 6 or Free Vend by Single Selection

7 = 7 or Free Vend by Row

8 = 8 or Free Vend by Machine

9 = 9 or Increment Price

FREE VEND BY SINGLE SELECTION

Enter the service mode by depressing the mode switch on the controller board. Depress the "6" key on the front panel keypad. A single beep will acknowledge. The LCD display will indicate "Make Selection".

Enter the desired selection from the front panel keypad--a single beep will acknowledge, the selection price will be displayed and a single product will be dispensed. If the product dispense cycle is successful, the credit display will blank and the system will remain in the service mode until the next service operation is initiated or 25 seconds have elapsed.

If the product dispense cycle is unsuccessful, three beeps will sound, the credit display will blank and the system will remain in the service mode until the next service operation is initiated or 25 seconds have elapsed.

FREE VEND BY ROW

Enter the service mode by depressing the mode switch on the controller board.

Depress the "7" key on the front panel keypad, a single beep will acknowledge.

The LCD display will indicate "Make Selection".

Enter the desired row (alpha) selection from the front panel keypad--a single beep will acknowledge, the selection prices will be displayed and a row of products will be dispensed in sequence. If the product dispense cycle is successful, the credit display will blank and the system will remain in the service mode until the next service operation is initiated or 25 seconds have elapsed.

If the product dispense cycle is unsuccessful, three beeps will sound, the credit display will show "Diagnostic Mode" and the system will remain in the service mode until the next service operation is initiated or 25 seconds have elapsed.

FREE VEND BY MACHINE

Enter the service mode by depressing the mode switch on the controller board.

Depress the "8" key on the front panel keypad, a single beep will acknowledge, the selection prices will be displayed and product will be dispensed in sequence. If the product dispense cycle is successful, the credit display will blank and the system will remain in the service mode until the next service operation is initiated or 25 seconds have elapsed.

If the product dispense cycle is unsuccessful, three beeps will sound, the credit display will show "Diagnostic Mode" and the system will remain in the service mode until the next service operation is initiated or until 25 seconds have elapsed.

PRICE SETTING PROCEDURE

- Enter the service mode by depressing the mode switch on the controller board.
- Enter the desired selection from the front panel keypad—a single beep will acknowledge.
- To increase the vend price, press the “9” key. The price will increase at the rate of 5 cents each ¼ second. To decrease the vend price, press the “4” key. In addition, a beep will sound each time the price changes.
- Setting prices for more than one selection is done in the Price Setting Copy Mode. Before copying prices, set the first selection in the same manner as the single price setting routine. Once the first price has been set, depress the “5” key to place the controller in the Price Copy Mode. Enter the desired selection to receive the copied price. Depress the “0” key to return to the service mode or wait until the service mode times out. Be sure to place correct price decals on dispenser before leaving the location.

The three switches below the “Mode” switch are used as “Inventory” switches for the Coinco 9302L and the MARS TRC 6010 coin mechanism.

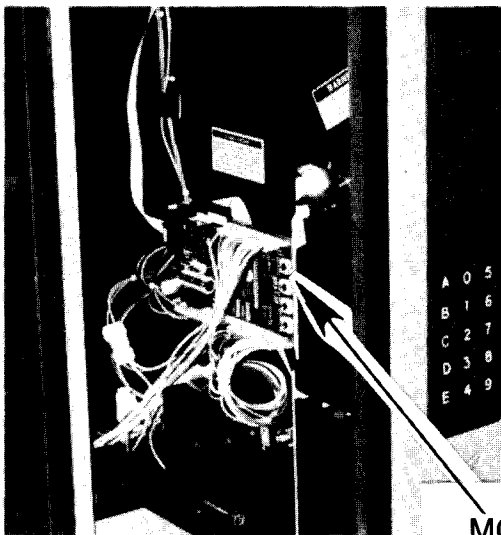

MODE
SWITCH

SLIDE OUT ELECTRICAL PANEL



CUSTOMER DISPLAY
AND SWITCH PANEL

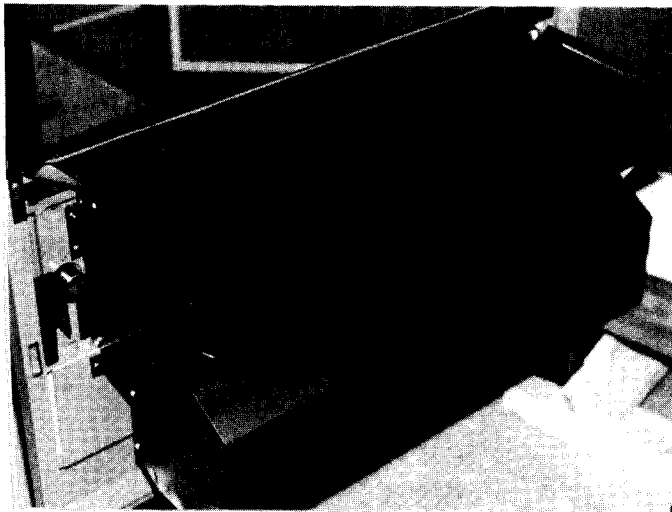

DELIVERY COMPARTMENT

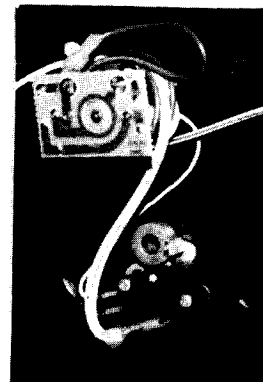

D.C. MOTOR ASSEMBLY



VARIOUS VIEWS OF MAKA DOLLAR BILL VALIDATOR

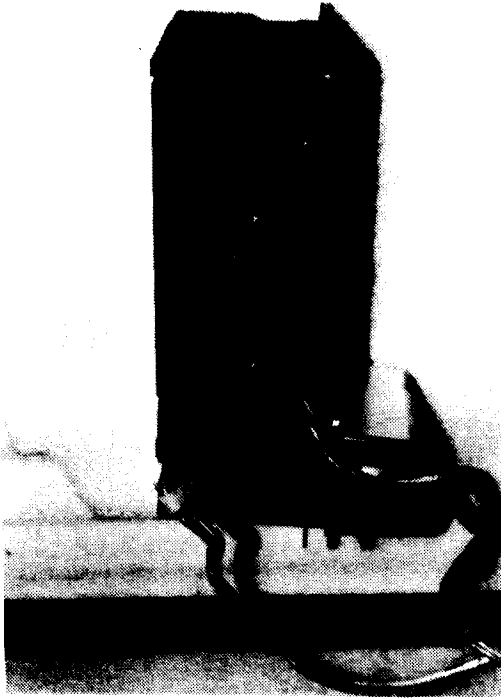

When a \$1 bill is inserted with front side up and lengthwise into the bill insertion opening the bill is automatically drawn in and discriminated.

If the bill is authentic, it will be automatically accepted and stacked; if judged to be counterfeit it will be returned. Stacker capacity is 115 bills.



ELECTRICAL TROUBLE SHOOTING

MACHINE WILL NOT ACCEPT COINS

- Make sure it is plugged into the wall outlet. (Look to see if fluorescent lamp is on.)
- Check for credit on the machine by attempting a selection.
- Check machine for leveling. (Such a condition can cause rejected coin to drop through rejector mechanism.)
- Check type of coin changer in machine. It must be a 24 volt Coinco C-300-E or 9302L Coinco or MARS TRC 6010.
- Check to make sure that coin return lever is fully released. If it is not releasing, clear and repair or replace acceptor mechanism.
- Remove the black cap fuse and check for a loose connector plug on the controller board or other electronic component.
- **CAUTION! CAUTION!**
Before attempting to remove the controller board, or display board or coin changer, remove the red cap fuse or unplug the machine from the wall outlet. This is to prevent damage to the boards and coin changer.

MACHINE WILL ACCEPT ALL COINS BUT . . .

- No selection can be made.
 - Does display show amount of coins inserted?
 - If Customer display is blank, check the manual payout switch on the changer. If the payout motor will not operate, the changer or controller is defective. Also, check all connector plugs on controller board for proper connection.
 - If display is blank and the manual payout switch will operate the payout motor—check for defective display cable, display or controller.
 - If display shows garbage—replace display.
 - If display shows proper amount of coins inserted and you get **no beep** or beeps when pushing a selector button—check for a defective selector switch or a bad connection at the selector switch by using FREE MODE for that selection.



- Only one selection cannot be made.
 - Determine fault by substituting an operational motor assembly in this position and pressing mode switch on controller. If motor assembly now functions properly, the replaced one needs repair. If not, the wiring is faulty.

CONTROLLER BOARD AND CUSTOMER DISPLAY BOARD

- If customer display is blank and the manual payout will not operate the payout motor—defective controller board or there is no power to the machine.
- If customer display is blank, and the payout motor will operate—check controller board, display, or cable.
- If display shows all 8's but machine will vend—replace display.
- Display shows garbage—display or controller board is defective.

Refer to DIAGNOSTICS portion of "Electrical Service" for additional service information.

CANDY TRAY ASSEMBLY C-30

ITEM	PART NO.	DESCRIPTION	QTY.
—	19272-10C	Tray Assembly	
1	18821	Nut-Hex 1/4-20, Center Lock	6
2	2614-BLK	Screw - #8-18 x 1/2	21
3	18365-3CC	Motor - DC Coinco 360	10
4	17843-BLK	Tray Divider	9
5	19321	Screw - #8-18 x 3/8	10
6	17537	Coupling - Plastic Hub	10
7	18925	Tray Front - Candy	5
8	19264-FBK	Tray - W. A. - Sliding	1
9	17403	Roller - Tray	6
10	18389	Harness - Sliding Tray	1
11	80569	Tie - Harness	1

CANDY TRAY ASSEMBLY C-20

ITEM	PART NO.	DESCRIPTION	QTY.
—	19272-8C	Tray Assembly	
1	18821	Nut-Hex 1/4-20, Center Lock	6
2	2614-BLK	Screw - #8-18 x 1/2	17
3	18365-3CC	Motor - DC Coinco 360	8
4	17843-BLK	Tray Divider	7
5	19321	Screw - #8-18 x 3/8	8
6	17537	Coupling - Plastic Hub	8
7	18925	Tray Front - Candy	4
8	19264-MBK	Tray - W. A. - Sliding	1
9	17403	Roller - Tray	6
10	18389	Harness - Sliding Tray	1
11	80569	Tie Harness	1

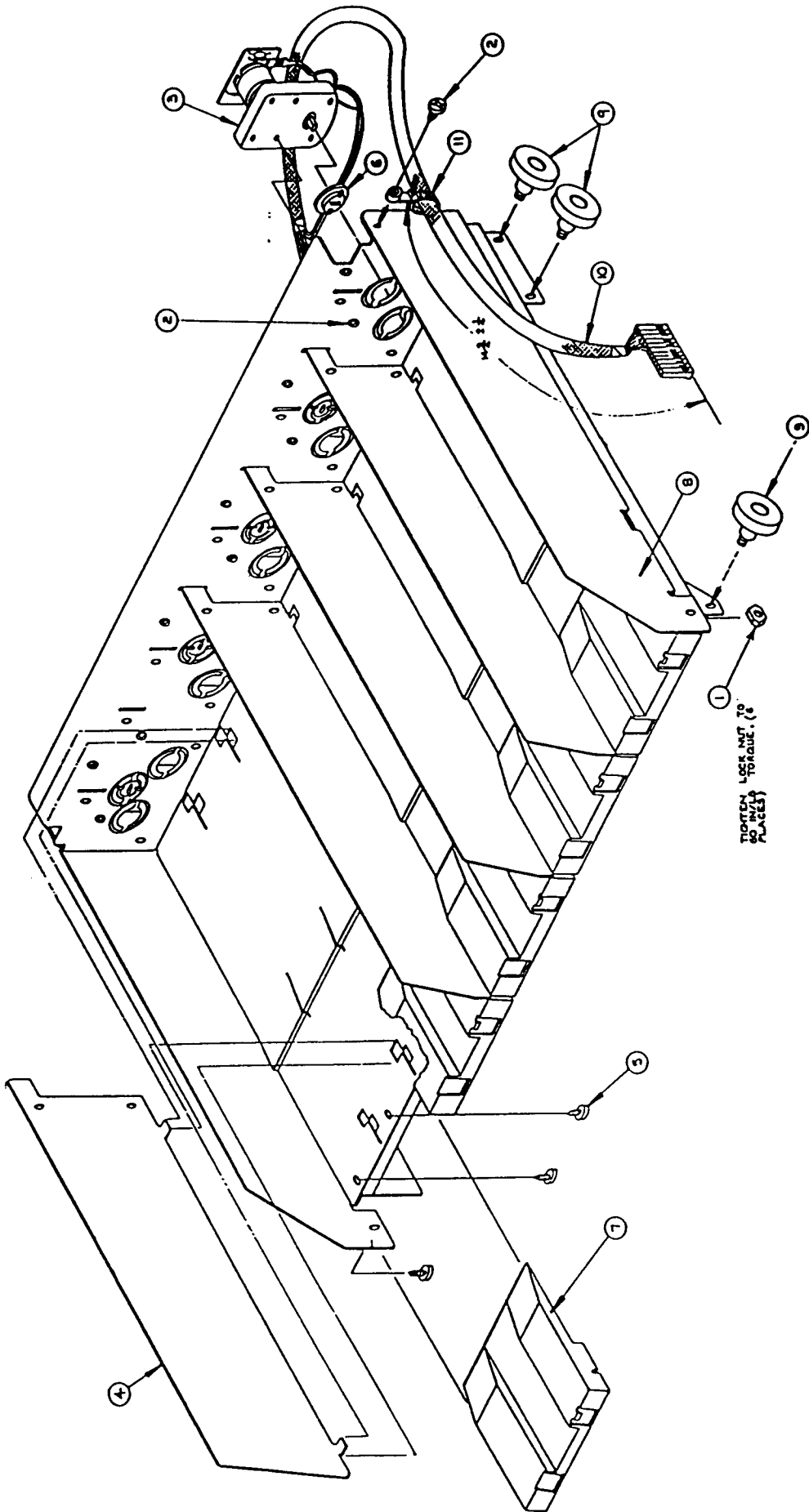

PASTRY TRAY ASSEMBLY C-30

ITEM	PART NO.	DESCRIPTION	QTY.
—	19272-5C	Tray Assembly	
1	18821	Nut - Hex 1/4-20, Center Lock	6
2	2614-BLK	Screw - #8-18 x 1/2	11
3	18365-3CC	Motor - DC	5
4	17843-BLK	Tray Divider	4
5	19321	Screw - #8-18 x 3/8	10
6	17537	Coupling - Plastic Hub	5
7	18926	Tray Front - Pastry	5
8	19264-FBK	Tray - W. A. - Sliding	1
9	17403	Roller - Tray	6
10	18388	Pastry Tray Harness	1
11	80569	Tie Harness	1

PASTRY TRAY ASSEMBLY C-20

ITEM	PART NO.	DESCRIPTION	QTY.
—	19272-4C	Tray Assembly	
1	18821	Nut - Hex 1/4-20, Center Lock	6
2	2614-BLK	Screw - #8-18 x 1/2	9
3	18365-3CC	Motor - DC	4
4	17843-BLK	Tray Divider	3
5	19321	Screw - #8-18 x 3/8	8
6	17537	Coupling - Plastic Hub	4
7	18926	Tray Front - Pastry	4
8	19264-MBK	Tray - W. A. - Sliding	1
9	17403	Roller - Tray	6
10	18388	Pastry Tray Harness	1
11	80569	Tie Harness	1

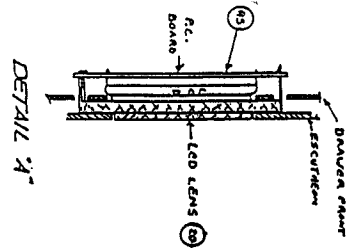
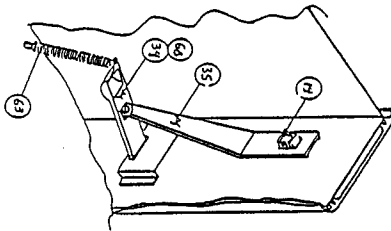
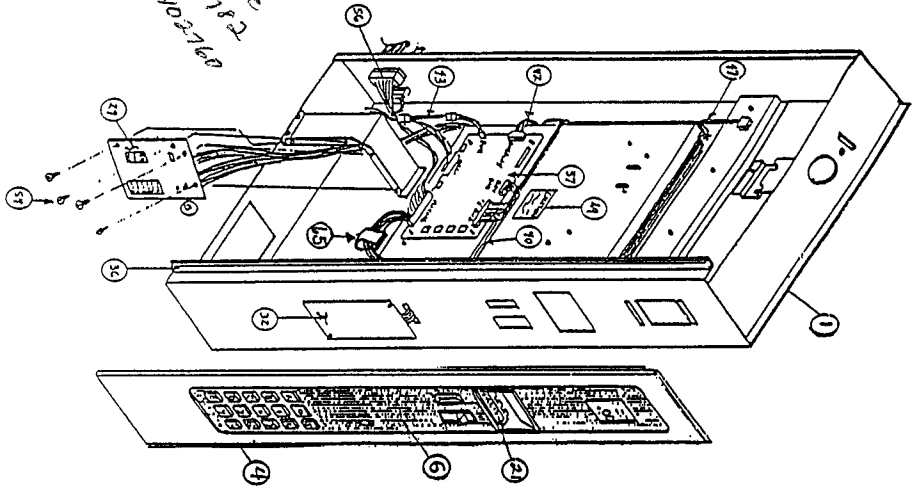
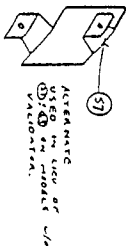
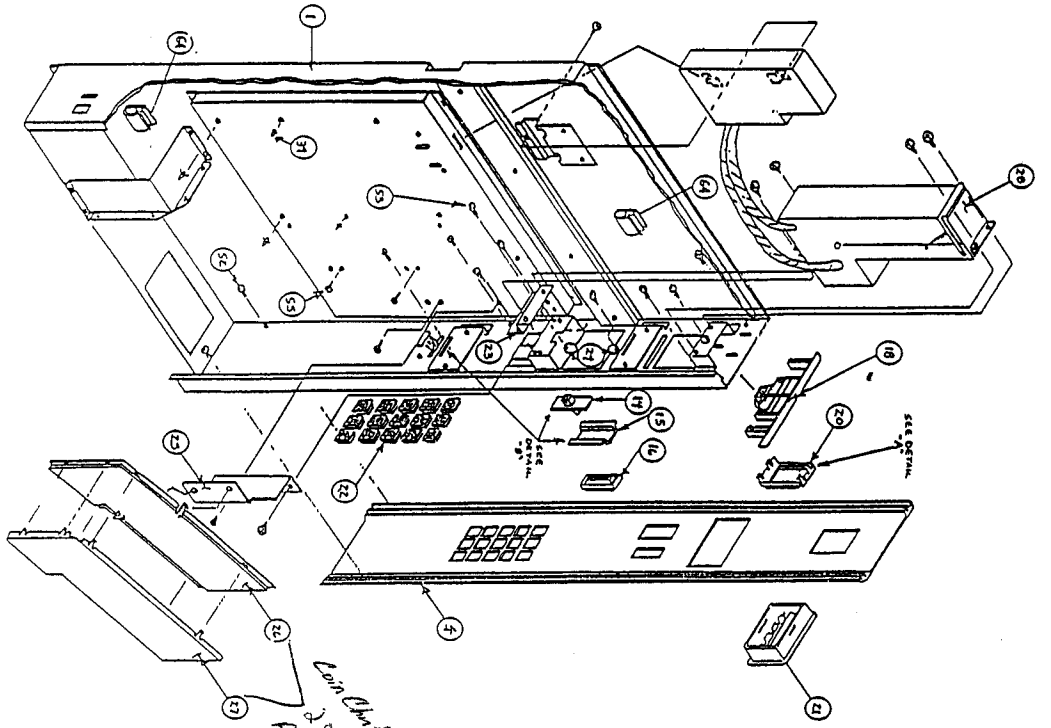

SLIDING DRAWER ASSEMBLY

ITEM	PART NO.	DESCRIPTION	QTY	QTY
—		Sliding Drawer	18041-TWO	18041-TWV
1	17922-SGB	Drawer W/A Sliding	1	1
4	17959-CSV	Escutcheon-Mid Drawer	1	1
6	18069-TWO	Decal - Escutcheon	1	
6	18069-TWV	Decal - Escutcheon		1
14	17904	Scavenge Slide	1	1
15	17901	Holder Scavenge Slide	1	1
16	17948	Insert Coin - US	1	1
18	17916-BLK	Cap - Mid-Escutcheon	1	1
20	17310	Lens - Readout	1	1
21	18039-BLK	Insert - Validator		1
22	18274-A}E, 0 & 9	Button-Selection	(Set) 1	(Set) 1
23	17771-BLK	Bracket - Validator Mtg.		1
24	18144-BLK	Retainer - Val. Insert		2
25	18063-BLK	Bracket - Coin Chute	1	1
26	17804	Rear - Coin Chute	1	1
27	17803	Cover - Coin Chute	1	1
28	18034	Validator - Maka 24V		1
29	19331	Bracket Ass'y - Jones	1	1
32	17878-CA	Key Pad - CA	1	1
34	17798-BLK	Plate - Scavenge	1	1
35	17800	Link - Scavenge	1	1
36	810-00	Strip-Neoprene (2.8 ft)	1	1
37	17656	Controller - CA	1	1
39	11808	Support - Circuit BD	4	4
40	18605	Cable - Key Pad Ext.	1	1
42	17907	Cable Display	1	1
43	17928	Harness - Power	1	1
45	17937	Display CA - LCD	1	1
47	17977-CA	Harness CA - Maka		1
49	17390	Decal - Caution	1	1
52	13140	Screw #10 Pan	6	7
53	1298-BLK	Screw #8 Pan	5	11
54	1868-BLK	Screw #8 Pan	5	5
55	11894	Screw #8	3	3
56	17902	Harness - Interconnect	1	1
57	18145-BLK	Filler - Validator	1	
63	611	Extension Spring	1	1
64	8538-02	Clamp - Harness	1	2
65	19316	Clamp - Ribbon Cable	1	1

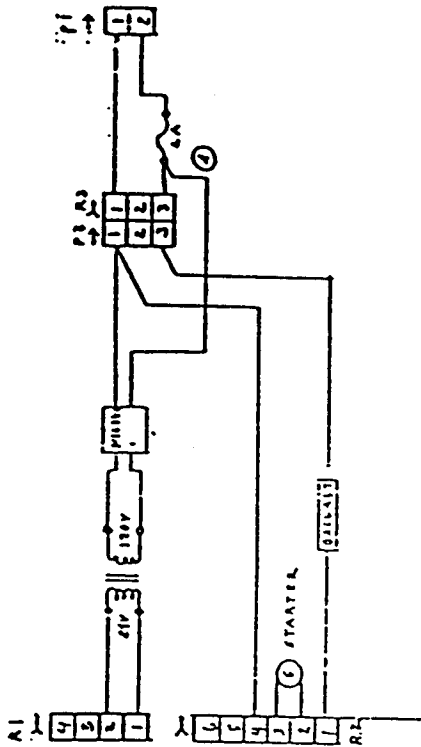
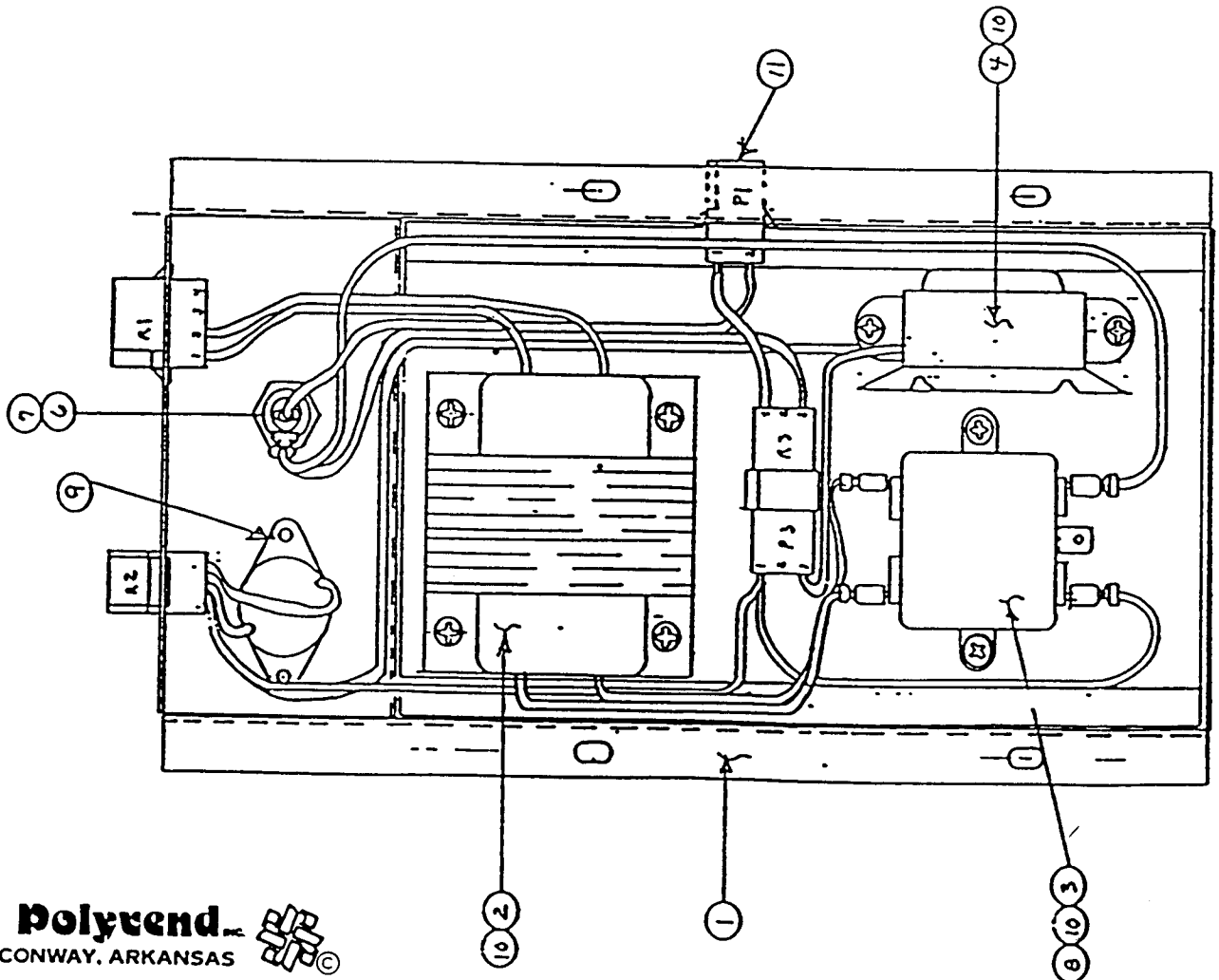

**POWER BOX ASSEMBLY
C-30**

ITEM	PART NO.	DESCRIPTION	QTY.
—	18011	Full Size Pwr Box Ass'y	
1	17987-BLK	Power Box W/A	1
2	17941	Transformer - 24V - 10V	1
3	17913	RFI Filter	1
4	17915-120	Ballast Assy, 120V	1
6	2091	Fuse Holder	1
7	2086-1	Fuse 2.0 Amp	1
8	266	Washer #8 Internal Tooth	1
9	2050-21	Screw 6-32 x 3/8	2
10	1298-BLK	Screw	8
11	17914	Harness - Fuse	1

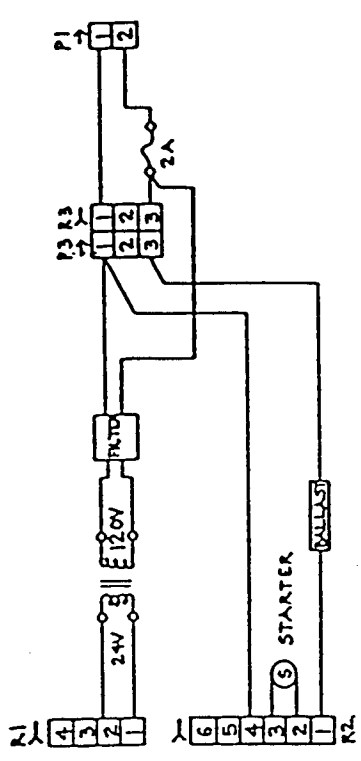

**POWER BOX ASSEMBLY
C-20**

ITEM	PART NO.	DESCRIPTION	QTY.
—	18868	Mid Size Pwr Box Ass'y	
1	17987-BLK	Power Box W/A	1
2	17941	Transformer - 24V - 10V	1
3	17913	RFI Filter	1
4	18870-120	Ballast Assy, 120V	1
5	2091	Fuse Holder	1
6	2086-1	Fuse 2.0 Amp	1
7	266	Washer #8 Internal Tooth	1
8	2050-21	Screw 6-32 x 3/8	2
9	1298-BLK	Screw	8
10	17914	Harness - Fuse	1

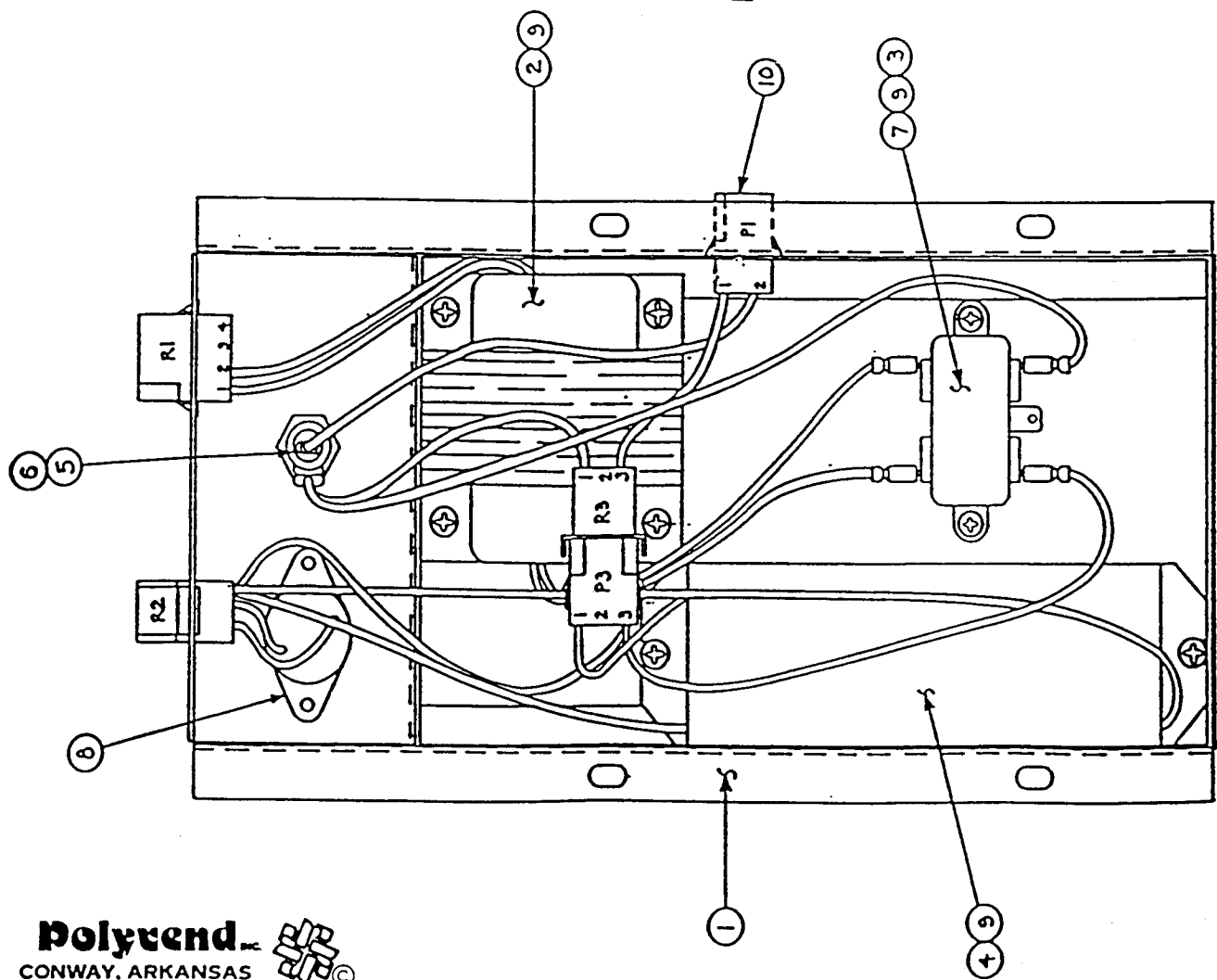

DELIVERY DOOR ASSEMBLY

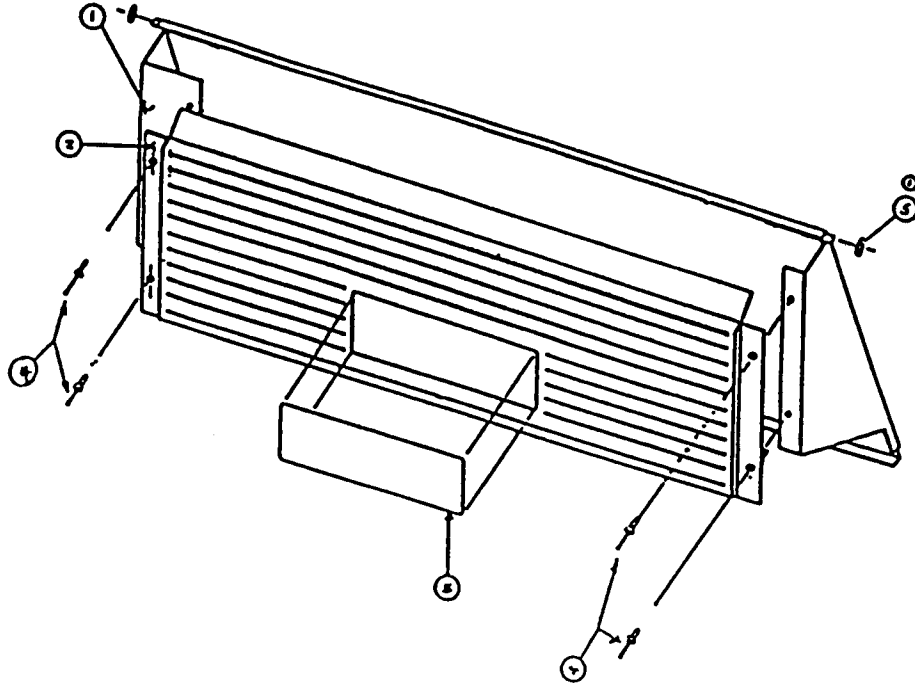

DELIVERY COMPARTMENT

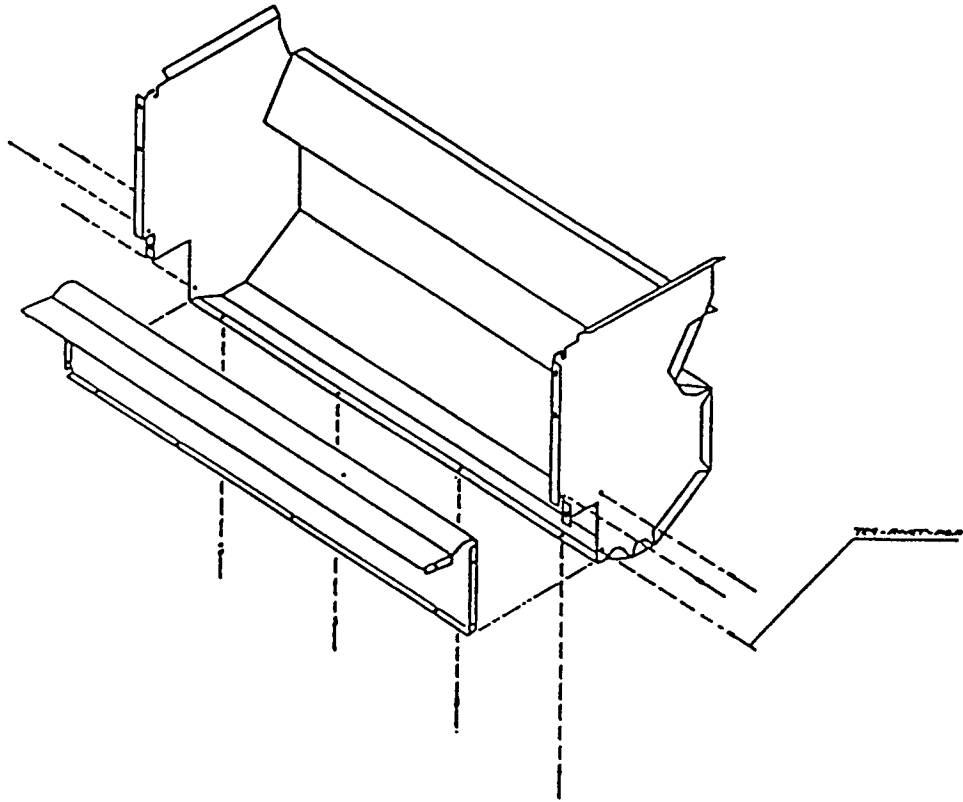

DELIVERY DOOR ASSEMBLIES
Full Size Machine
C-30

ITEM	DESCRIPTION	"PUSH"	
		BLK/BLK	QTY
—	Door Assembly - Delivery	18042	
1	Door W/A - Del Rear	18031-BLK	1
2	Door Del - Front	17931-BLK	1
3	Decal	18037	1
4	Rivets	729	4
5	Washer - 1/4 Nylon	18684	2

DELIVERY COMPARTMENT ASSEMBLY
Full Size Machine
C-30

1 18687

DELIVERY DOOR ASSEMBLY
Mid Size Machine
C-20

ITEM	DESCRIPTION	"PUSH"	
		BLK/BLK	QTY.
—	Door Assembly - Delivery	18516	
1	Door W/A - Del Rear	18031-BLK	1
2	Door Del - Front	18512-BLK	1
3	Decal	18037	1
4	Rivets	729	4
5	Washer - 1/4 Nylon	18684	2

DELIVERY COMPARTMENT ASSEMBLY
Mid Size Machine
C-20

1 18492

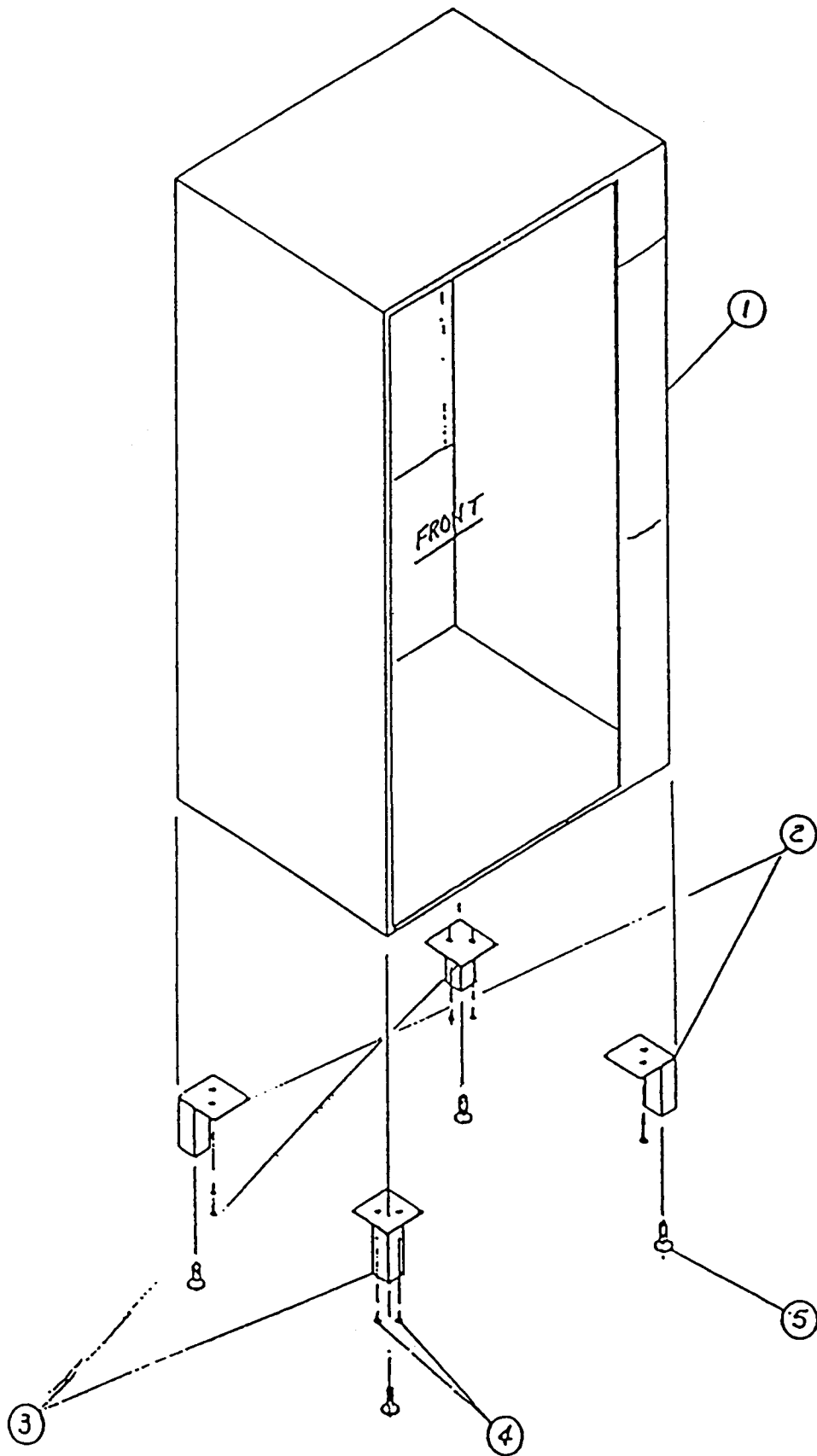

**CABINET SHELL ASSEMBLY
FULL SIZE
C-30**

		SPECIFY COLOR
1 Cabinet	18862-DB 18862-RED	Dark Brown Red
2 Leg & Plate	18747-R.H.	Black
3 Leg & Plate	18747-L.H.	Black
4 Screw 1/4-20	318	
5 Leg Equalizer	12766	

**CABINET SHELL ASSEMBLY
MID SIZE
C-20**

		Specify Color
1 Cabinet	18497-DBS 18497-RDS	Dark Brown (Short Glass) Red (Short Glass)
2 Leg & Plate	18747-R.H.	Black
3 Leg & Plate	18747-L.H.	Black
4 Screw 1/4-20	318	
5 Leg Equalizer	12766	

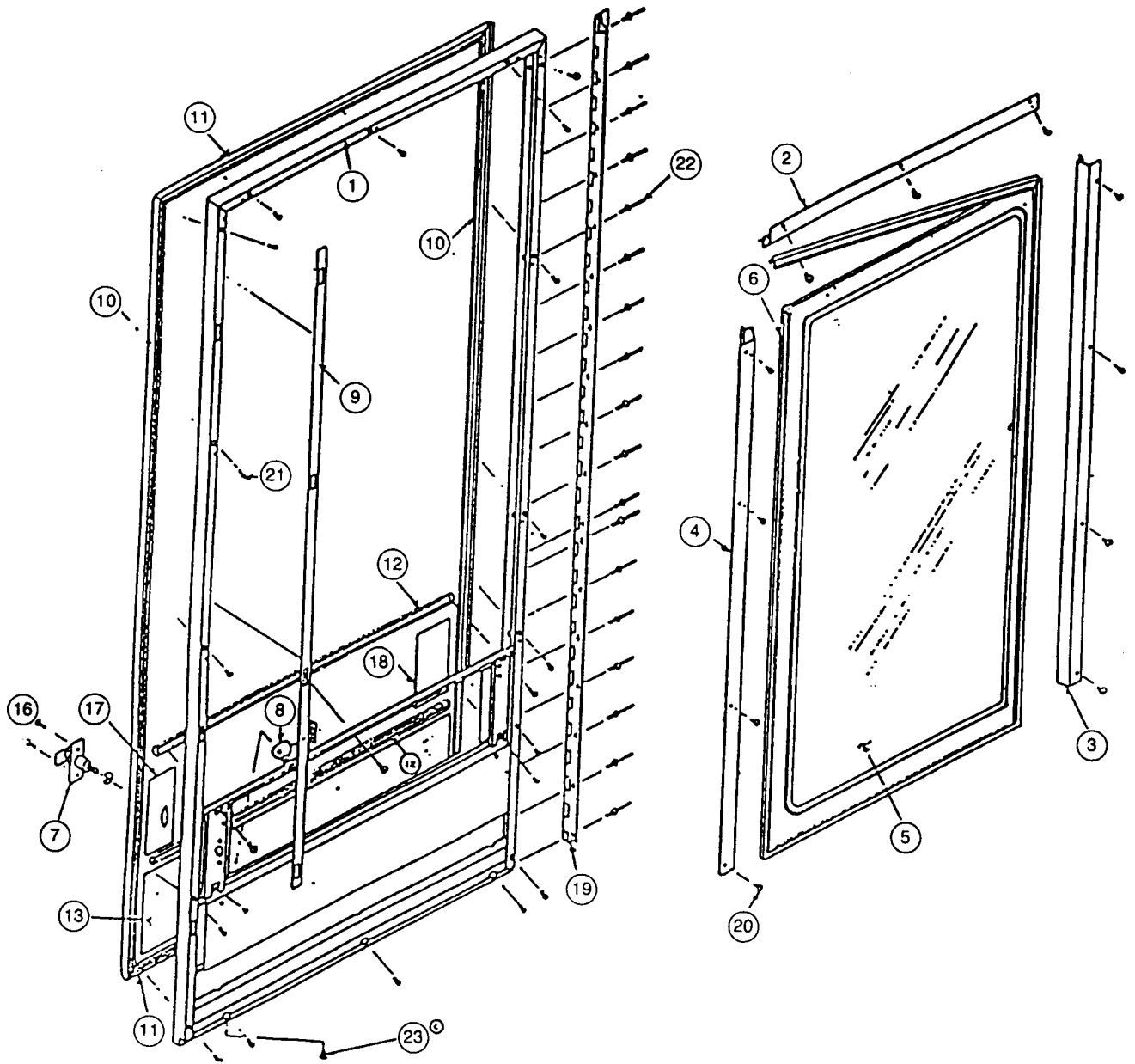

FULL SIZE SERVICE DOOR ASSEMBLY C-30

ITEM	DESCRIPTION	PART NO.	QTY.
—	Door Assembly - Service	18040-RED	
1	Door W/A - Service	17924-RED	1
2	Holder - Glass-Top	17934-BLK	1
3	Holder - Glass-LH	17954-BLK	1
4	Holder - Glass-RH	17954-BLK	1
5	Glass - Service Door	18221	1
6	Gasket - Service Door	17970	12
7	Lock Asy - Srvc Door	14325-BLK	1
8	Cam - Lock, Service	17457-BLK	1
9	Bar W/A - Locking	18001-BLK	1
10	Trim - LS & RS Door	17955-BLK	2
11	Trim - Door-Top & BTM	17957-BLK	2
12	Trim - Del Comp. Mid	17967-BLK	2
16	Screw #10-24	746	2
17	Panel - Decor R.H.	17932-BLK	1
18	Panel - Decor L.H.	17933-BLK	1
19	Hinge - Service Door	18774-RED	1
20	Screw	1868-BLK	11
21	Screw	18033	19
22	Rivet	729	18
23	Retaining Plug	18442	1
24	Trim - Service Door Hinge	18873-RED	1

MID SIZE SERVICE DOOR ASSEMBLY WITH SHORT GLASS C-20

ITEM	DESCRIPTION	PART NO.	QTY.
—	Door Assembly - Service	18510-RED	
1	Door W/A - Service	18508-RED	1
2	Holder - Glass-Top	18499-BLK	1
3	Glass Holder - Side LH	18504-LBK	1
4	Glass Holder - Side RS	18504-RBK	1
5	Glass - Service Door	18762	1
6	Gasket - Service Door	17970	12
7	Lock Asy - Srvc Door	14325-BLK	1
8	Cam - Lock, Service	17457-BLK	1
9	Bar W/A - Locking	18509-BLK	1
10	Trim - LS & RS Door	17955-BLK	2
11	Trim - Door-Top & BTM	18501-BLK	2
12	Trim - Del Comp. Mid	18502-BLK	2
16	Screw #10-24	746	2
17	Panel - Decor R.H.	17932-BLK	1
18	Panel - Decor L.H.	17933-BLK	1
19	Hinge - Service Door	18774-RED	1
20	Screw	1868-BLK	11
21	Screw	18033	19
22	Rivet	729	18
23	Retaining Plug	18442	1
24	Trim - Serv Door Hinge	18873-RED	1